

MHCP Heavy-Duty Cartridge Precleaner

Massive, Rugged, Ready to Work

The MHCP Heavy-Duty Cartridge Precleaner features segmented SuperShear™ blades that are engineered to stand up to the most abusive beltline conditions, such as wet, sticky fire clay, and maintain constant cleaning force. The massive blades have an extended wear life and also a quick-change blade cartridge feature. This is an extreme-duty cleaner that gets the job done – and with minimal maintenance.

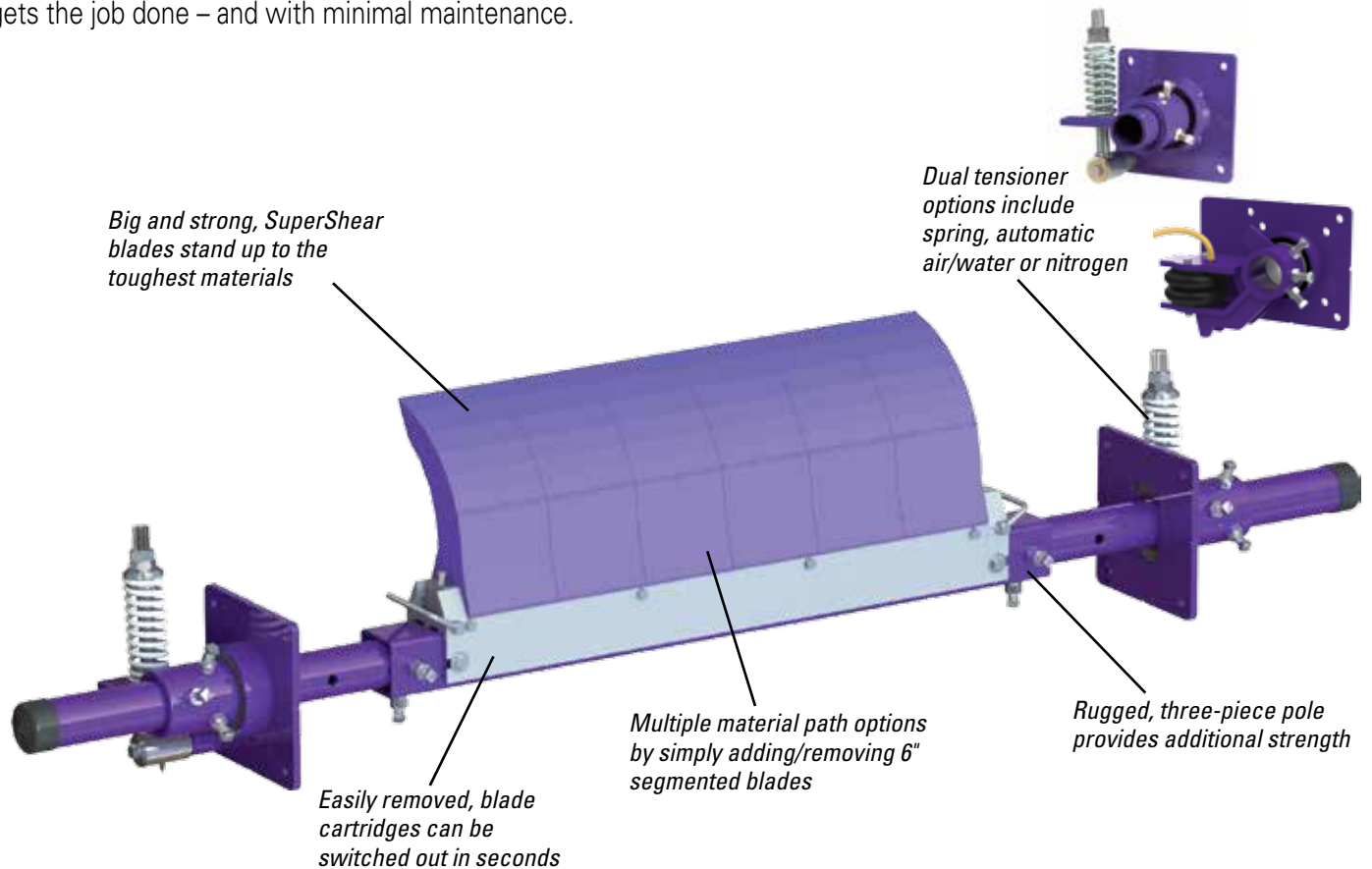

Features and Benefits

- **Works with mechanical fasteners.** The shock-absorbing tensioners allow mechanical splices, skived or unskived, to pass without damage to the splice or the cleaner and with minimal cleaning disruption.
- **Retrofits to other cleaners.** The MHCP blade cartridge will fit on the poles of other cleaner manufacturers. Now you can experience the benefits of the SuperShear blades without having to install a completely new cleaner.
- **Complete cleaning system.** When teamed with the MHS HD Secondary Cleaner, it makes up a system that delivers maximum cleaning power for the most abusive conveyor applications.
- **Made for mining conveyors.** Made from heavy-duty, corrosion-resistant steel, the MHCP is available in sizes for belt widths from 24" to 96" (600 to 2400mm). Additional sizes are available upon request.

MHCP Heavy-Duty Cartridge Precleaner

Maximum Belt Speed

1200 FPM (6 M/sec)

Temperature Rating

-30° F to 180° F (-35° C to 82° C)

Minimum Pulley Diameter

20" (500 mm)

Blade Height

14" (350 mm)

CEMA Cleaner Rating

Class 5

Usable Blade Wear Length

8" (200 mm)

Blade Material

Urethane 90 durometer (proprietary blend for abrasion resistance and long wear)

Available for Belt Widths

24" to 96" (600 to 2400 mm)

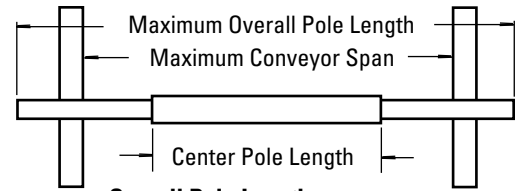

Overall Pole Length

Cleaner size + 58" (1450 mm)

Maximum Conveyor Span

Cleaner size + 42" (1050 mm)

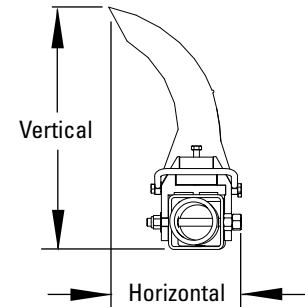

Horizontal Clearance Required

7" (175 mm)

Vertical Clearance Required

19" (475 mm)

Ordering Information

MHCP HD Cartridge Precleaner with Spring Tensioner (PST)					
Belt Width		Blade Coverage		Ordering Number	Item Code
in.	mm	in.	mm		
24	600	18	450	MHCP-24S	75929
30	750	24	600	MHCP-30S	75930
36	900	30	750	MHCP-36S	75931
42	1050	36	900	MHCP-42S	75932
48	1200	42	1050	MHCP-48S	75933
54	1350	48	1200	MHCP-54S	75934
60	1500	54	1350	MHCP-60S	75935
72	1800	66	1650	MHCP-72S	75936
84	2100	78	1950	MHCP-84S	76800
96	2400	90	2250	MHCP-96S	78955

Lead time: 1 working day

Blade Cartridge Kits (Includes blades, cartridge, and mounting bolts)			
Belt Width		Ordering Number	Item Code
in.	mm		
24	600	MHCP-BCK24	75953
30	750	MHCP-BCK30	75954
36	900	MHCP-BCK36	75955
42	1050	MHCP-BCK42	75956
48	1200	MHCP-BCK48	75957
54	1350	MHCP-BCK54	75958
60	1500	MHCP-BCK60	75959
72	1800	MHCP-BCK72	75960
84	2100	MHCP-BCK84	76810
96	2400	MHCP-BCK96	78957

NOTE: For easy blade changeout, remove cartridge with worn blades and replace with new blade cartridge kit. New blades can then be installed in the old cartridge for the next changeout.

Lead time: 1 working day

MHCP HD Cartridge Precleaner with Portable Air Tensioner (PAT)					
Belt Width		Blade Coverage		Ordering Number	Item Code
in.	mm	in.	mm		
24	600	18	450	MHCP-24P	78723
30	750	24	600	MHCP-30P	78724
36	900	30	750	MHCP-36P	78725
42	1050	36	900	MHCP-42P	78726
48	1200	42	1050	MHCP-48P	78727
54	1350	48	1200	MHCP-54P	78728
60	1500	54	1350	MHCP-60P	78729
72	1800	66	1650	MHCP-72P	78730
84	2100	78	1950	MHCP-84P	78731
96	2400	90	2250	MHCP-96P	78959

Lead time: 1 working day

Pole Location Chart			
A	X	Y	C
20"	10"	14 3/8"	17 1/2"
21"	10 1/2"	14 3/8"	17 3/4"
22"	11"	14 3/8"	18 1/8"
23"	11 1/2"	14 3/8"	18 3/8"
24"	12"	14 3/8"	18 3/4"
25"	12 1/2"	14 3/8"	19"
26"	13"	14 3/8"	19 3/8"
27"	13 1/2"	14 3/8"	19 3/4"
28"	14"	14 3/8"	20 1/8"
29"	14 1/2"	14 3/8"	20 3/8"
30"	15"	14 3/8"	20 3/4"
31"	15 1/2"	14 3/8"	21 1/8"
32"	16"	14 3/8"	21 1/2"
33"	16 1/2"	14 3/8"	21 7/8"
34"	17"	14 3/8"	24 1/4"
35"	17 1/2"	14 3/8"	22 5/8"
36"	18"	14 3/8"	23"
37"	18 1/2"	14 3/8"	23 3/8"
38"	19"	14 3/8"	23 7/8"
39"	19 1/2"	14 3/8"	24 1/4"
40"	20"	14 3/8"	24 5/8"
41"	20 1/2"	14 3/8"	25"
42"	21"	14 3/8"	25 1/2"
43"	21 1/2"	14 3/8"	25 7/8"
44"	22 1/4"	14 3/8"	26 1/2"
45"	22 7/8"	14 3/8"	27"
46"	23 1/2"	14 3/8"	27 1/2"
47"	24"	14 3/8"	28"
48"	24 5/8"	14 3/8"	28 1/2"

Pole Location Specs

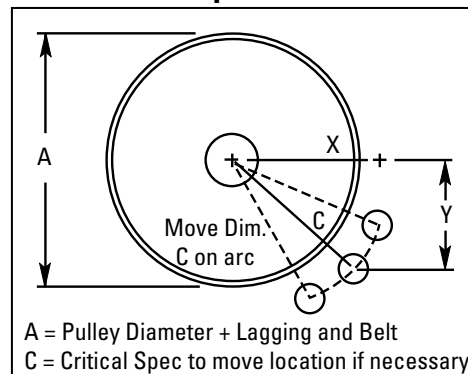

Distribution in Europe by:

Flexco Europe GmbH • Leidringer Strasse 40-42 • D-72348 Rosenfeld • Germany

Phone: +49-7428-9406-0 • Fax: +49-7428-9406-260 • E-mail: europe@flexco.com • Web: www.flexco.com



2525 Wisconsin Avenue • Downers Grove, IL 60515-4200 • USA

Tel: (630) 971-0150 • Fax: (630) 971-1180 • E-mail: info@flexco.com

Visit www.flexco.com for other Flexco locations and products.

Authorized Distributor:

